

Multifunction pump for handling gaseous liquids in process engineering

Pumping liquids with a high gas content can be problematic, causing sharp losses in head and flow or even total cessation of pump flow. German pump manufacturer SERO believes its Multifunction SRZS Pumps provide the ideal solution for such challenging situations, offering a combination of the advantages of side-channel and radial flow centrifugal pump hydraulics. Together these achieve high pump heads, even at relatively high gas entrainments, combined with low NPSH values.

Many applications in processing plants require pumps that are – at least temporarily – able to handle liquids with gas or vapour entrainments, without risk of flow interruption.

Liquids pumped near their boiling point, such as condensates, liquified gases, hydrocarbons, aerosols or refrigerants, demand a lot of a pump. The operator should attempt to eliminate all risks. Radial centrifugal pumps allow only limited gas entrainments in the pumped liquid; with slight gas contents of ca. 5% their head and flow decline dramatically. Higher gas contents cause total interruption of the pump flow.

The SERO Multifunction Pump SRZS, a side-channel pump of special construction (Figure 1), has no prob-

lems with gas inclusions, even under extreme conditions. For example, during venting of the suction line, the SRZS has the outstanding ability to reliably deliver the gas with the help of only a small amount of liquid left in the pump.

Design features and operating principles

The multifunction pump combines the advantages of two pumping systems:

- the side-channel pump hydraulics for gas transport allow the pump to attain pump heads that are up to four times greater than that generated by radial flow centrifugal pumps;
- the radial flow centrifugal pump hydraulics of the inlet stage helps

achieve extremely low NPSH values.

Priming process

During the process of priming, operation of the side-channel pump hydraulics is similar to that of a gas handling vacuum pump or a compressor. The side-channel pump has the ability to work temporarily as a liquid ring vacuum pump and therefore may also be considered as a rotary displacement pump. Similar to the operating principle of a liquid ring vacuum pump, a circulating liquid ring has a displacement effect, the auxiliary liquid entering (piston-like) the impeller and the side channel and exiting during each circulation. The centrifugal effect causes collection of the liquid in the outer region of the side channel and impeller cells and thus forms the liquid ring, which is necessary for the priming process. The gas builds up in the inner region.

The special arrangement of the side channel gives the liquid ring an eccentric course, bringing about the displacement effect of the liquid ring vacuum pump. The produced vacuum allows an independent venting or degassing of the suction line and a priming of the liquid (Figure 2a). The operation of the multifunction pump as a mere vacuum pump is only possible over a limited period. Non-supply of further auxiliary liquid at normal temperature leads to a gradual heating and finally to a vaporization

Figure 1. Cutaway diagram of SERO's SEMA-S side-channel, multifunction pump with magnetic drive.

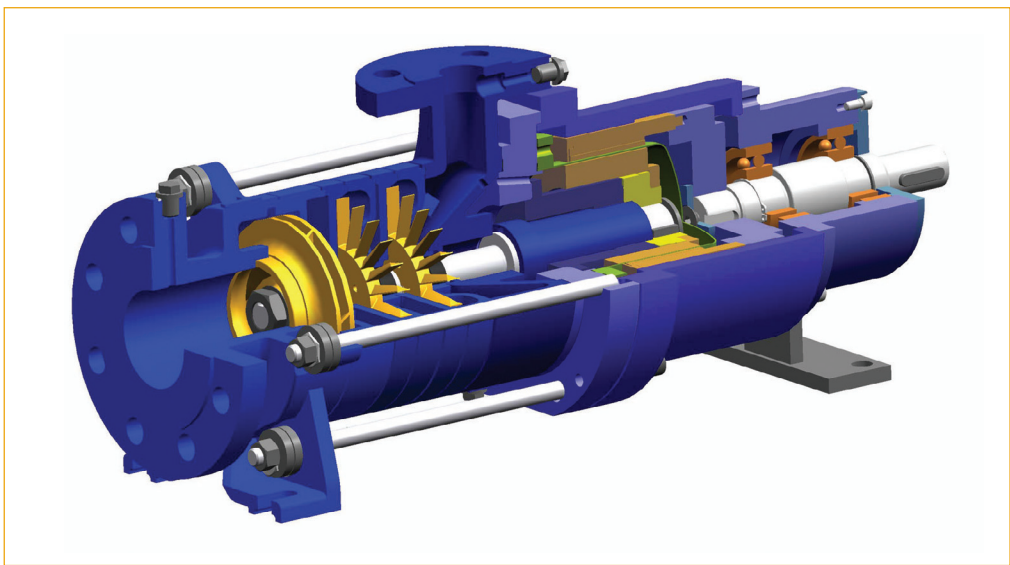

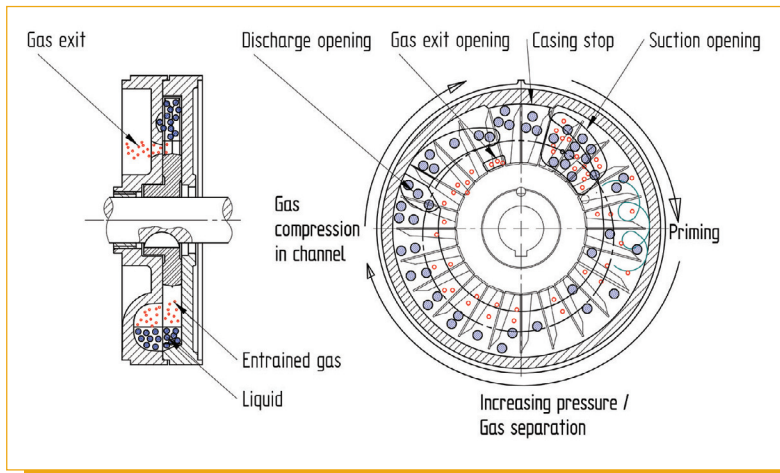

Figure 2. The principles of the operation of the side-channel pump hydraulics: (a) gas delivery; (b) liquid delivery.

of this liquid.

The multifunction pump has gained widespread use because of its unique advantage of insusceptibility to vapour or gas inclusions in the pumped liquid and at the same time its ability to achieve substantial heads. Gas bubbles are entrained through the pump along with the liquid, with a maximum allowable gas content of 50%. Liquid-gas mixtures can be handled pump-free with no need of any auxiliary devices. Gas contents of 10%, for example, have virtually no impact on the steeper characteristic curve compared with radial flow centrifugal pumps (Figure 3).

Commonly a side-channel pump is called 'self-priming', whereas 'self-venting' would be a much better description. The self-venting effect is a great advantage in the process of partial vaporization. Even at the very beginning of cavitation, the performance (Q-H) curve of a normal centrifugal pump drops steeply, whereas the flow of the multifunction pump does not break down.

The ability to handle such a high gas content is not common for all pumps of this type. Minor constructional modifications may have a great impact on the gas-handling ability. For example, the US type of side-channel pump – known as the 'peripheral', 'regenerative' or 'turbine' pump – was modified to be more efficient, yet can only handle small gas contents. In contrast, the multifunction pump is capable of

handling relatively high gas volumes.

Liquid transfer

After initial priming, the flow process changes automatically from displacement over mixture transport (with liquid being pumped as a foam-like mixture into the pressure area), to pure liquid transfer. When completely filled with liquid, the multifunction pump can be considered as a normal centrifugal pump.

However, the specific way the pumped liquid is directed through the side-channel pump hydraulics gives it a substantially higher energy than that attained with conventional impellers of radial design. This higher pressure figure must be considered as a significant advantage over 'normal' centrifugal pumps.

On its way from the inlet to the outlet of the side channel, the pumped liquid circulates many times in between the individual vane spaces. Pressure is created as the sum of individual impulses during pump circulation. This process is an 'inner multistage effect' (Figure 2b). With a centrifugal pump, impeller diameter and revolutions per minute determine the volume speed that is transferred into pressure (pressure figure = 1). The total pressure of the multifunction pump is created as an accumulation of impulses, with a pressure figure of about 4.

The specific flow through the side-channel stages with intended variations causes a little decrease in pump

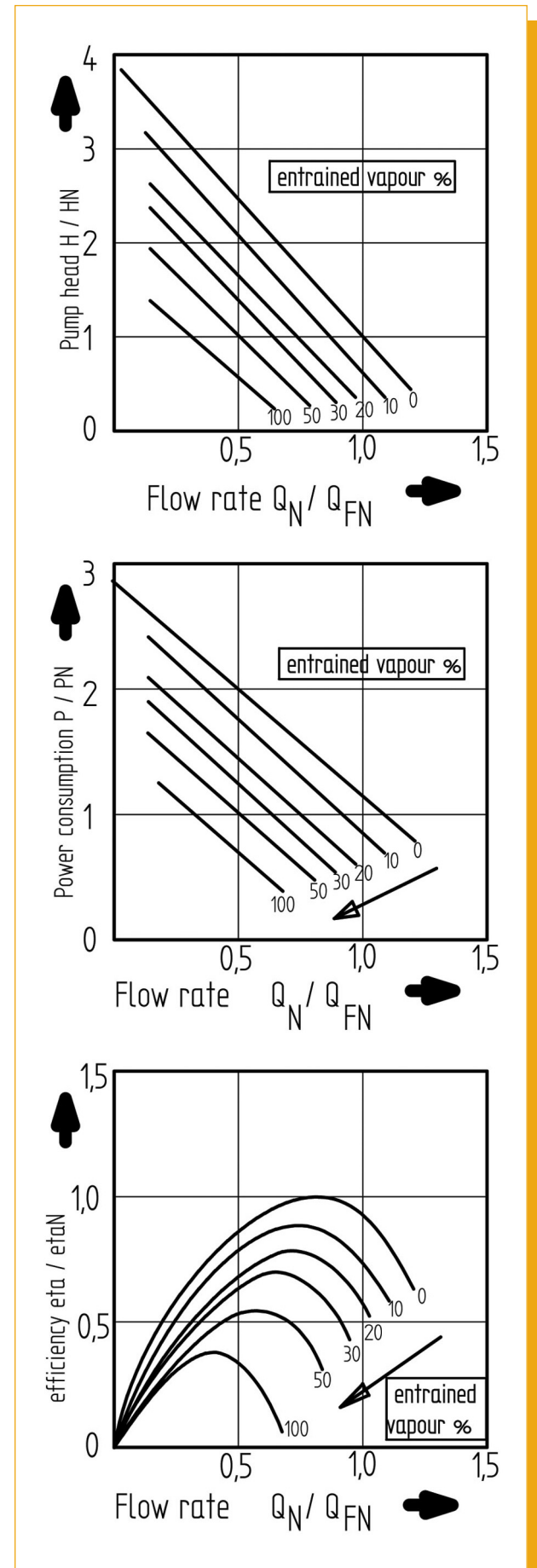
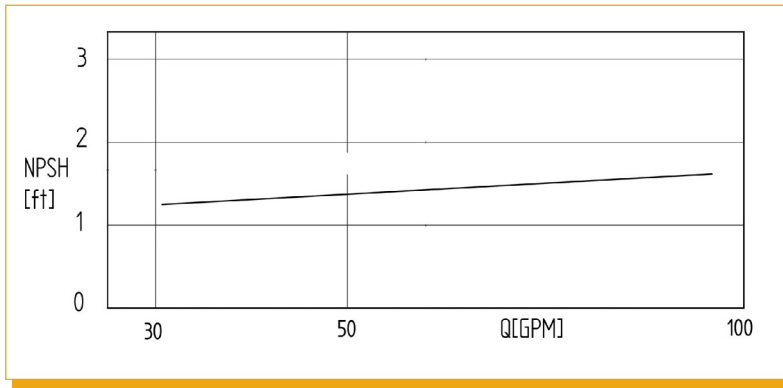

Figure 3. Impact of air contents on the characteristic curves of a multifunction pump.

Figure 4. Comparison of the efficiencies of multifunction and centrifugal pumps in their typical n_q application ranges.



efficiency, as do losses caused by partial flows at the clearance surfaces of the impeller hub, which are necessary for hydraulic impeller balancing and for lubrication. Optimal casting techniques and highly precise manufacturing technologies allow achieved efficiency rates of up to 40%.

Multifunction pumps are used for applications where other pump types or technologies can not attain better efficiencies or where other pump designs require higher expenditure on plant and/or pump design. As a rule, this is the case at low flows and middle to high heads, i.e. at low specific revolutions per minute, n_q , of 8 to 10. At these working points the efficiency rate is above that of centrifugal pumps that are running at low flows in a partial load range with reduced efficiency (Figure 4).

Power consumption of the multifunction pump is approximately one third below that of standard water pumps (DIN EN 733) and standard chemical pumps (DIN EN 735).

Extremely low NPSH value

The multifunction pump combines the advantages of side-channel pumps, to handle high gas entrainments and to be self-priming, with the principle of a centrifugal stage, as the first step towards achieving lower NPSH values. In addition, its suction casing has a flow-friendly axial inlet that is provided with a specially designed large cross-section, allowing low flow speeds. These slow flow speeds help the multifunction pump to bring about low NPSH values at the inlet into the suction impeller. The radial suction impeller is also designed according to the latest

insights into cavitation to achieve specially low NPSH values.

The head produced by the suction impeller is sufficient to reliably develop the necessary inlet pressure for the next side-channel stage, even under the most unfavourable working conditions.

The low motor speed of $n = 1450$ rpm (at 60 Hz, $n = 1750$ rpm), which is possible due to the high pressure figure, allows the multifunction pump to have lower NPSH values compared to a faster running pump. Another advantage of this pump's slow speed is its extended lifetime, as a consequence of a combined mastering of mechanical loads, partial load behaviour and noise.

The NPSH values are between 20 cm (0.6 ft) and 1 m at $n = 1450$ rpm, depending on the required flow. This allows inlet heads of less than 0.5 m (1.5 ft) for boiling liquids (Figure 5), resulting in substantial savings on system costs.

The lower its specific speed, the better the priming ability of the pump and the lower the risk of cavitation.

The multifunction pump has no definite fixed cavitation limit line but an area in which the pump can be operated without cavitation. At variable vapour pressure, the multifunction pump is considerably less susceptible to cavitation than a radial flow centrifugal pump. With this increased operational safety, the multifunction pump guarantees trouble-free production processes.

Figure 5. Net positive suction head curve for the multifunction pump.

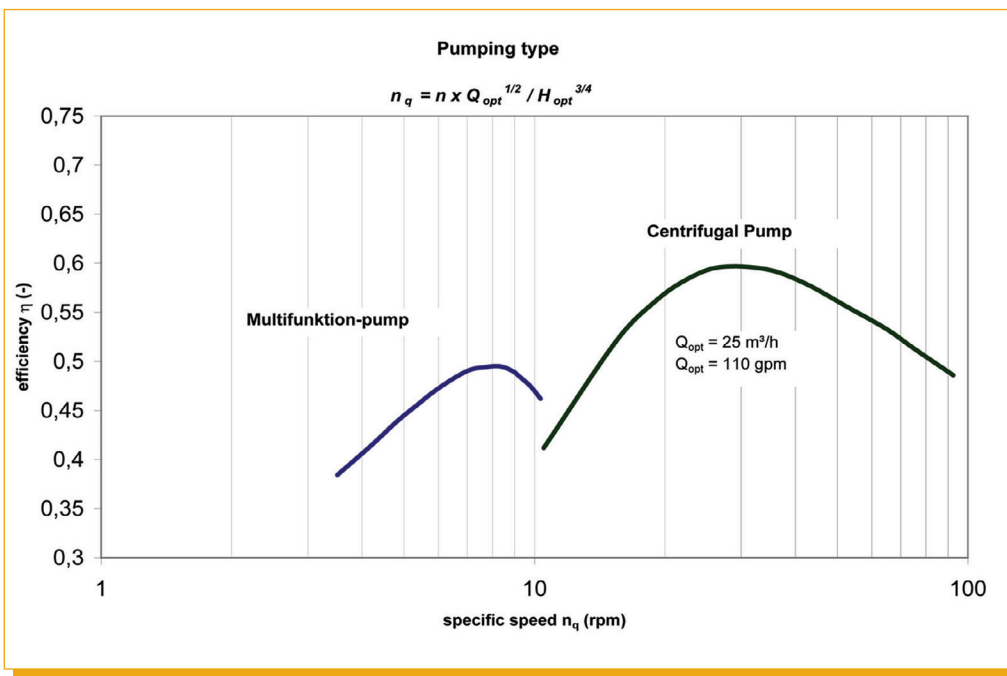

In practice

As with conventional radial flow centrifugal pumps, the flow of a multifunction pump is proportional to speed, whereas the head varies with the square. However, the operating principle is completely different.

The multifunction pump has a different power curve from a centrifugal pump. Its power consumption reduces with increasing flow, so that the old

centrifugal pump ‘law’ – to start the pump only against a closed valve – is not valid. Multifunction pumps must **never** be operated against a closed discharge line.

Centrifugal and multifunction pumps also differ considerably in their performance (Q-H) curves: the side-channel multifunction pump has a steep, almost straight performance curve (Figure 6a). This characteristic allows a very exact throttle regulation, because changes of the on-site counter pressure entail only small changes of the pump flow rate.

With reference to the overall operating process, slight pressure deviations only have a small influence on the multifunction pump’s flow.

It is not possible to vary the pressure of a multifunction pump by remanufacturing the impellers. However, due to the very distinct graduation of the various types, this pump adapts exactly to the required working conditions, with the advantage of relatively good efficiencies over the whole performance range.

Pumps are required to adapt to variable working conditions, that is, they need to be controllable during operation. The almost linear pump curve of the multifunction pump favours exact pressure-dependent control in processing services, while the NPSH curve must of course always be observed. Possible regulation methods are speed control by means of a frequency converter

and throttling in the discharge line, or bypass. In the case of bypass regulation, the bypass flow should not be circulated directly into the suction line but into the suction tank, for technical reasons.

Before the first start-up, the multifunction pump must be filled – at least partially – with the pump liquid, to ensure that the liquid ring necessary for proper operation can be formed. For all subsequent starts enough liquid is kept within the pump.

Trouble-free operation in process circulations

The proven technology of the multifunction pump (Figure 7) has been applied in thousands of applications and is the optimal solution for handling two phase flows (i.e. liquid–gas mixtures).

Applications for this pump type cover the transport of low boiling liquids, such as liquified gas, as well as the delivery of various refrigerants, such as ammonia (NH₃) or liquid carbon dioxide (CO₂), down to –60 °C.

Here, the required pump operation features are:

- insusceptibility to gas inclusions
- generation of relatively high differential pressures
- reliable seals
- large, axially arranged suction casing openings.

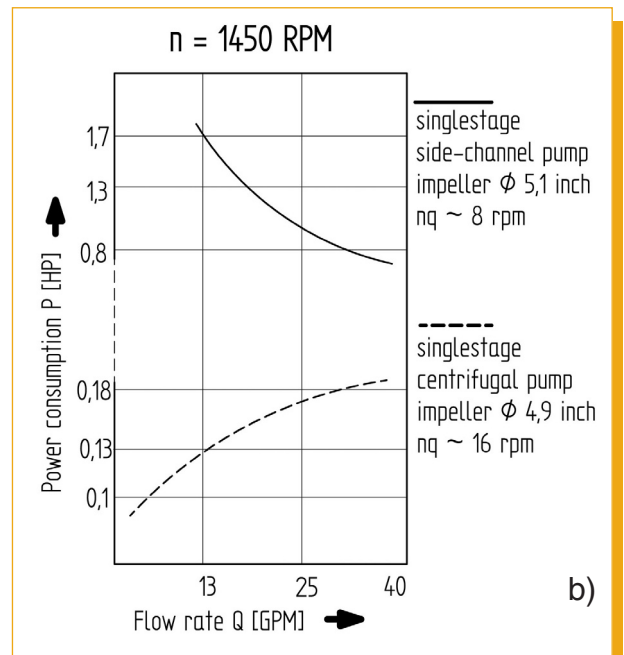
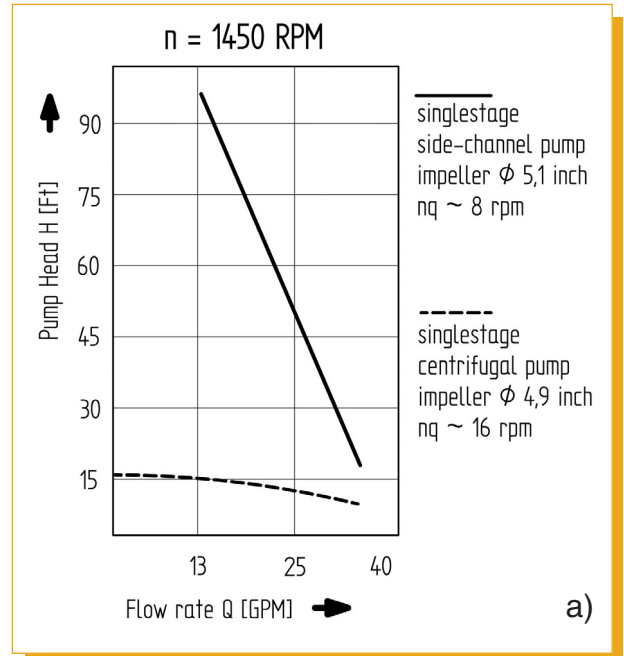

Figure 6. Comparison of (a) performance (Q-H), and (b) power consumption (p) curves of a radial centrifugal pump and a multifunction pump.

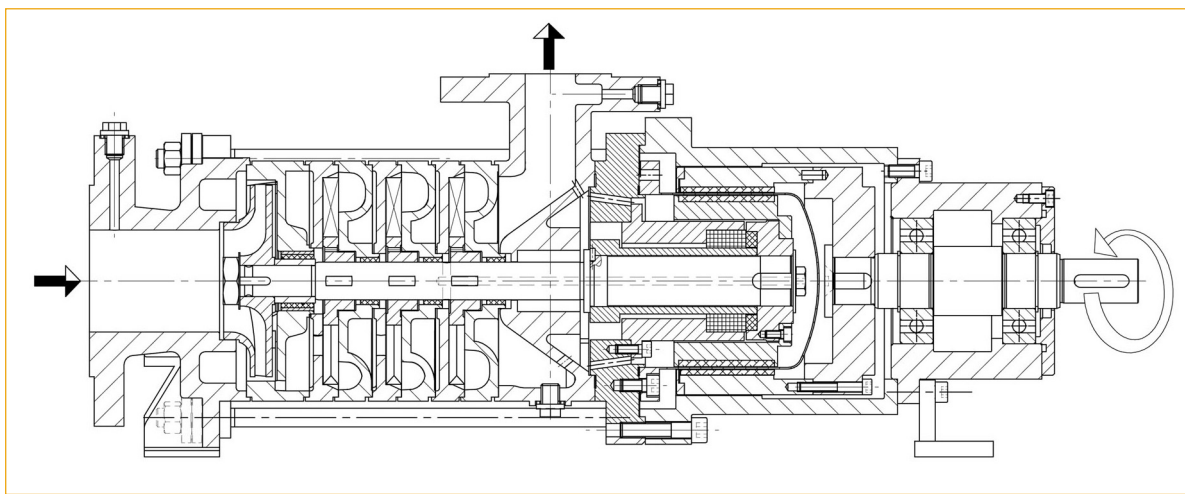

Figure 7. Cross-sectional diagram of the multifunction pump.

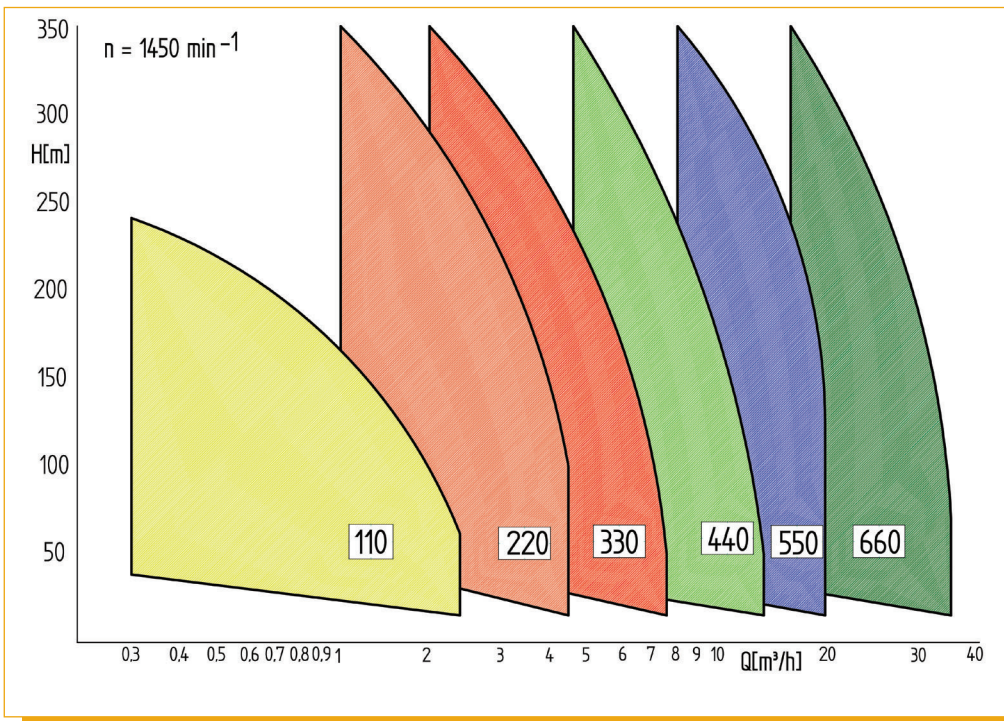

Figure 8. Characteristic head/flow curves for SERO's multifunction pumps.

For transportation of hydrocarbons, solvents and fuels in storage tank installations, use is made of the high self-priming ability to fully empty the

containers or road tankers. The pump's compact design is also a great advantage.

Another very important application of the multifunction pump is as a boiler feed or condensate pump for operating temperatures up to 180 °C; in short, wherever vapour is needed to keep a process running, e.g. in condensate recovery systems, hot water circulation or in distillate columns. The multifunction pump's low NPSH values and insusceptibility to cavitation make them a very suitable choice for these applications.

Within effective environmental protection, for example in flue gas desulphurization, these pumps are also an excellent choice for use in auxiliary installations, for example in neutralization of chemicals.

The multifunction pump is available for flows up to $Q = 35 \text{ m}^3/\text{h}$ (154 gpm) and heads up to $H = 300 \text{ m}$ (Figure 8).

The most usual construction is the processing design with a standard motor on a common baseplate. In addition, vertical inline and close coupled versions are available as options, on a limited performance basis.

Decisive factors for the selection of materials and sealing systems are the liquid being pumped and the operating conditions. Available materials range from cast iron through ductile iron to high grade stainless steel alloys. Shaft seals cover single and double acting mechanical seals.

If the demand is for sealless pumps, SERO offers magnetically driven or canned motor pumps.

User benefits

Total life cycle costs should be an essential factor to consider in pump selection. Instead of making high investments for expensive monitoring or diagnosis systems, the pump user should first make a correct pump selection.

In many cases, pumps are operated outside their designed performance range and therefore do not work optimally. Most pump failures occur due to NPSH problems, gas inclusions in the pumped liquid, dry run or operation outside their designed range, e.g. at too low a counter pressure.

The characteristics of the multifunction pump offer important advantages over the major causes of failure of 'normal' centrifugal pumps. Their good self-priming ability together with their insusceptibility to cavitation make them an ideal choice for handling liquids near their vapour pressure.

Due to their considerable pressure rating and the compact dimensions of a modular design, SERO believes its multifunction pumps are the optimal solution, technically and also economically, for low flow – high head applications involving low-viscous and pure liquids.

CONTACT

Albert L. Zientek
 SERO Pumpenfabrik GmbH & Co. KG
 Industriestraße 31, 74909 Meckesheim,
 Germany
 Tel: +49-6226-9201-0
 Fax: +49-6226-9201-40
 E-mail: info@seroweb.de
 www.seroweb.de

BURGMANN

Nova Magnetics-Burgmann

...the experts in
 magnetic drive technology

- High Efficiency Magnetic Couplings eliminate up to 99% of eddy current losses
- Ideal for high power, high pressure, or high torque applications

For further information contact:

USA & CANADA

Nova Magnetics - Burgmann Ltd.
 One Research Drive
 Dartmouth, Nova Scotia B2Y 4M9 Canada
 Phone: 902-465-6625
 Fax: 902-465-6629
 e-mail: info@novamagnetics.ca

EUROPE

Burgmann Dichtungswerke GmbH & Co.
 Äußere Sauerlacher Str. 6-10
 D-82502 Wolfratshausen
 Germany
 Phone: 49 8171 23-1486
 Fax: 49 8171 23-1526
 email: scherer@burgmann.com

www.novamagnetics.ca